

Product Information



Xclude™ Contamination Exclusion

.....

Xclude™ High Humidity Expansion Chamber Breather

*Protection from moisture and particulate
contamination in low-flow, steady-state operations*



Applications

- Totes
- Transformers
- Storage tanks
- Hydraulics

Highlights

- Expansion chamber and internal check-valve system create a nearly sealed system.
- Eliminates rust-forming condensation
- Prevents sludge deposits and water-contaminated oil
- Provides longer oil and filter life
- Reduces wear and tear on equipment, prolongs life



Xclude™ High Humidity Expansion Chamber Breather

By the Numbers

1–Domed Cap

Allows for better washdown runoff.

2–Expansion Chamber

Diaphragm allows for expansion/contraction of air within casing as a result of temperature variations during steady-state operations.

3–External Ribs on Shell

Create greater durability and grip when installing or replacing breather.

4–Integrated Nylon Standpipe

Provides excellent vibration resistance and dissipates impact throughout the unit, eliminating weak points. It also allows even airflow distribution throughout the unit, eliminating inaccurate readings of desiccant saturation.

5–Integrated Drip Ring

Prevents water from entering vent holes.

6–Threaded Mounting

Easily replaces standard filler/breather cap with multi-fit connection or one of several adapters.

7–Larger, High-Capacity Check Valves

Allow for increased airflow at low cracking pressure.

8–Polyester Filter Element

Removes airborne contamination to 3-micron absolute. Unique loops allow particles to release during system exhalation, helping to increase breather life.

9–Enhanced Seal

Eliminates potential for airflow bypass.



How It Works

As wet, contaminated air is drawn through the unit, multiple 3-micron polyester filter elements remove solid particulates while the color-indicating silica gel extracts moisture. The diaphragm allows for expansion/contraction of the air within the casing as a result of temperature variations during steady-state operations.

When air is expelled from the container, the top foam pad prevents oil mist from contacting silica gel or entering the atmosphere.

Specs



Materials & Components

- Housing: Polycarbonate, nylon 6/6 30% glass filled, polypropylene
- Seals (LEXHHEC375-28): Buna-N, EPDM, PVC
- Seals (LEXHHEC1-65): Buna-N, PVC
- Filter Media: Polyurethane, polyester
- Hydrophilic Media: Silica gel

Filter Efficiency

- 3μ absolute (β3≥200)

Recommended Temperature Range

- -20°F to 200°F (-29°C to 93°C)

Chemical Compatibility

- Compatible with all mineral oils, most synthetic oils and diesel. Contact your local consultant for chemical compatibility inquiries.

Certificates and Approvals

- Upon request

Breather Specifications

Model	Amount of Desiccant (lb / kg)	Adsorption Capacity (fl oz / ml)	Air Flow Rate (cfm @ 1 Psid)	Air Flow Rate (gpm / lpm)
LEXHHEC375-28	.3 / .1	2 / 50	1	11 / 40
LEXHHEC1-65	.8 / .4	5 / 144	7	44 / 84

Breather Sizing / Air Flow Guidelines

Model	Max Suction & Return Rate (gpm / lpm)	Gearbox & Storage Tank Reservoir Size (gallons / liters)	Hydraulic Reservoir Size (gallons / liters)
LEXHHEC375-28	11 / 40	50 / 189	NA
LEXHHEC1-65	44 / 84	400 / 1,514	55 / 208

Note: These are general guidelines for sizing; other considerations, such as: humidity level, frequency of air flow, ambient temperatures, and chemical compatibility are very important in sizing a breather properly. Larger applications and special circumstances require thorough analysis. Please contact LE for assistance in breather sizing for your application.

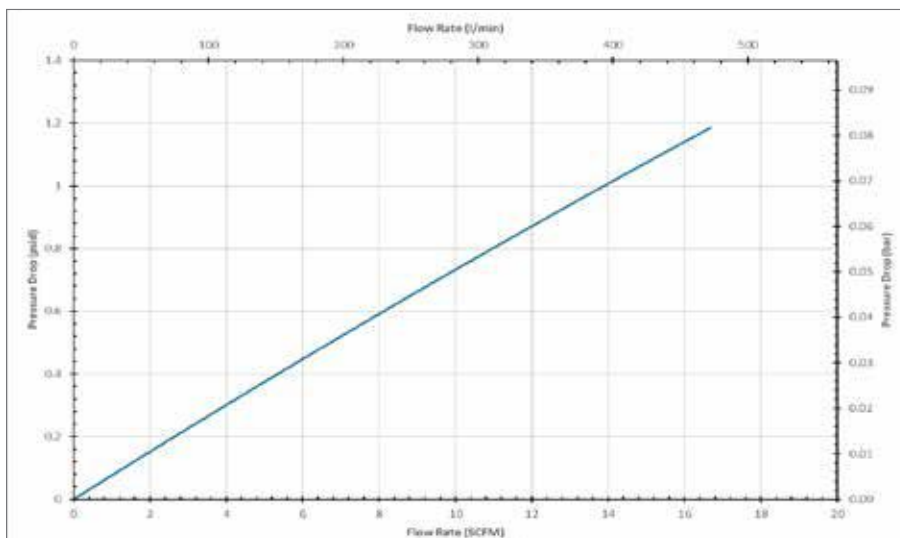

— LEXHHEC1-65

Did You Know?

Xtract High Humidity Expansion Chamber breathers were specifically designed for steady-state operations with minimal temperature fluctuations. These breathers provide excellent protection in continuous duty applications. For check-valve protection in intermittent operating conditions, try a Xtract High Humidity Check Valve breather instead.





Additional Specs

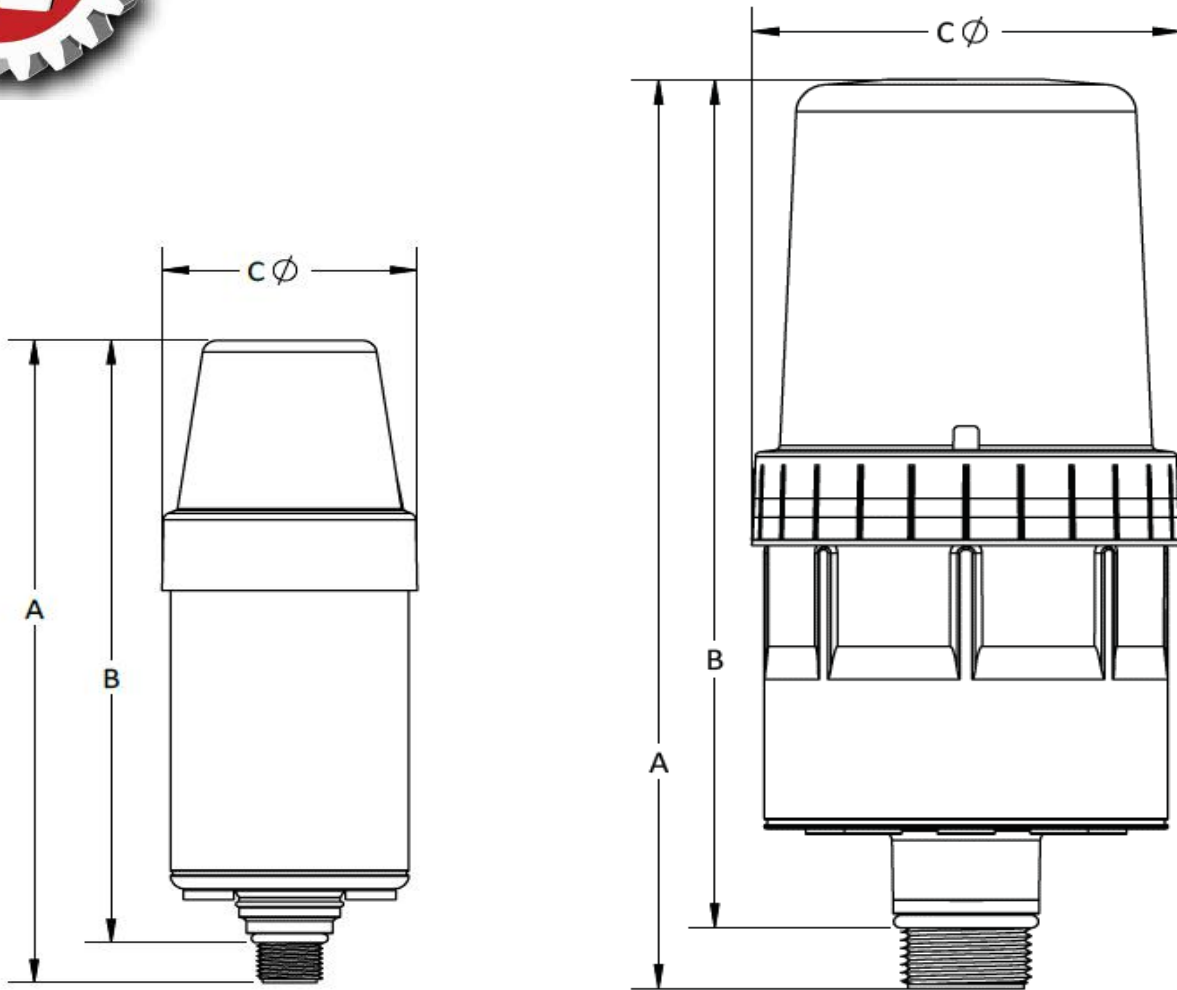

Breather Dimensions

Model	Style	Thread Size (Multi-Fit Male)	A (inch / mm)	B (inch / mm)	C (inch / mm)
LEXHHEC375-28	miniature	3/8" with O-Ring Seal, Compatible with: 3/8" NPT; 3/8" BSPT; 3/8" BSPP	7.187 / 182	6.742 / 171.2	2.52 / 64
LEXHHEC1-65	standard	1" with O-Ring Seal, Compatible with: 1" NPT; 1" NPSM; 1" BSPT; 1" BSPP	9.728 / 247.1	9.067 / 230.3	4.1 / 104